

ATCH SERIES REPLACEMENT COILS

STANDARD FEATURES



**FACTORY INSTALLED THERMAL
EXPANSION VALVE**
EMBOSSED GALVANIZED STEEL CASE
HEAVY RIFLED COPPER TUBING
ALUMINUM FINS
ALUMINUM END PLATES
PRESSURE TESTED TO 450 LBS.
DUAL RATED FOR R-22 AND R-410a
STANDARD POLYMER DRAIN PAN
**INSULATED CABINET WITH NO
EXPOSED FIBERGLASS INSULATION**

**5-YEAR LIMITED WARRANTY
AGAINST COIL LEAKAGE AND
DRAN PAN FAILURE.**
**1-YEAR FUNCTIONAL PARTS
WARRANTY.**

**3/4" MPT DRAIN
CONNECTIONS**

3/8" LIQUID LINE

SUCTION LINE CONNECTIONS
3/4" ON 1.5 TO 3.0 TONS
7/8" ON 3.5 TO 5.0 TONS

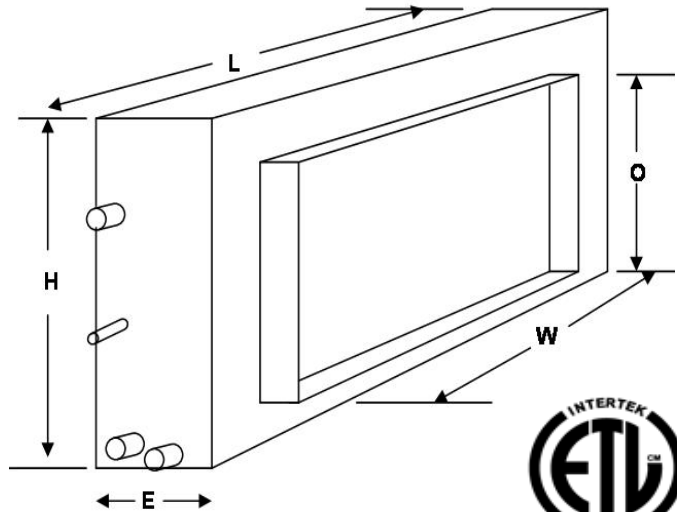

CABINET DIMENSIONS

Coil Model	Nominal Tonnage	Cabinet Depth L	Cabinet Height H	Cabinet Width E	Inlet/Outlet Width W	Inlet/Outlet Height O
ATCH-024	2.0	25.75	25.5	10	19.75	22
ATCH-036	3.0	25.75	25.5	10	22.25	22
ATCH-048	4.0	32	25.5	10	22.25	22
ATCH-060	5.0	32	25.5	10	22.25	22

Specifications may change without notice.