

ASLBH SERIES ASPEN REPLACEMENT COIL



STANDARD FEATURES

BI-DIRECTIONAL AIR FLOW
EMBOSSED GALVANIZED STEEL CASE
HEAVY RIFLED COPPER TUBING
ALUMINUM FIN
ALUMINUM END PLATES
PRESSURE TESTED TO 450 LBS.
DUAL RATED FOR R-22 AND R-410a
STANDARD POLYMER DRAIN PAN
INSULATED CABINET WITH NO
EXPOSED FIBERGLASS INSULATION

5-YEAR LIMITED WARRANTY
AGAINST COIL LEAKAGE AND
DRAN PAN FAILURE.
1-YEAR FUNCTIONAL PARTS
WARRANTY.

3/4" MPT DRAIN
CONNECTIONS

3/8" LIQUID LINE

SUCTION LINE CONNECTIONS
3/4" ON 1.5 TO 3.0 TONS
7/8" ON 3.5 TO 5.0 TONS

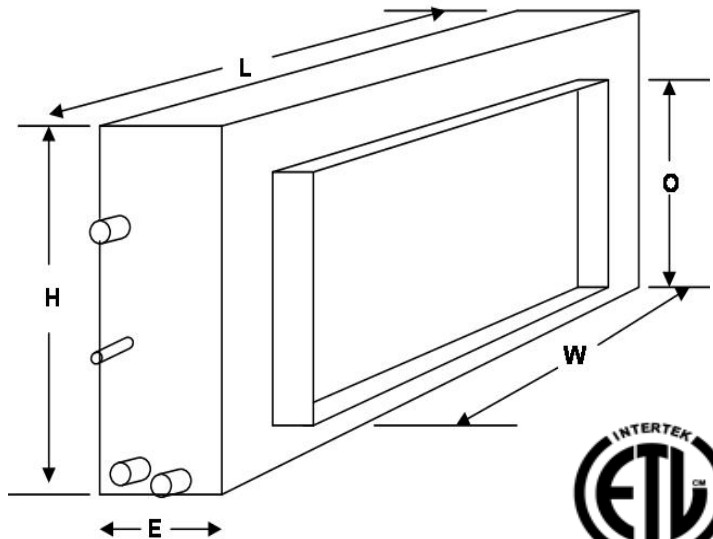

CABINET DIMENSIONS

Coil Model	Nominal Tonnage	Cabinet Number	Dim'n L	Dim'n H	Dim'n W	Dim'n O	Dim'n E
ASLBH-24	2.0	#1	27"	18"	21.5"	14.5"	10"
ASLBH-36	3.0	#1	27"	18"	21.5"	14.5"	10"
ASLBH-48	4.0	#2	36"	18"	29"	14.5"	10"
ASLBH-60	5.0	#3	36"	22"	29"	18.5"	10"

Specifications may change without notice.

NEXT