

Light Commercial Coils For York Furnaces

Features

- Copper Tube Aluminum Fin Design
- Embossed Galvanized Cabinet
- Coated G-90 Drain Pan
- Adjustable Expansion Valve Refrigerant Control

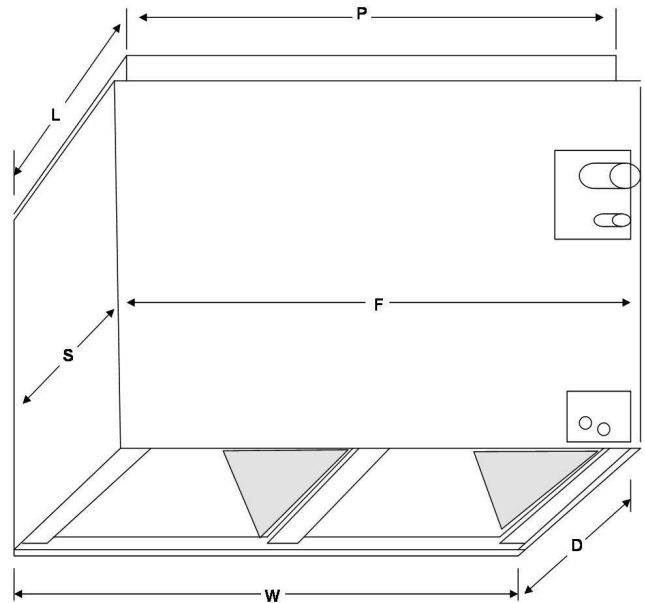

General Specifications

Model#	P	L	F	S	W	D	H	DRN SZ	SUC LN	LIQ LN	WT Lbs
ASM92Y	30.75	19.75	32.5	21.5	31.25	20.25	24.5	3/4	1 1/8	1/2	100
ASM110Y	30.75	19.75	32.5	21.5	31.25	20.25	24.5	3/4	1 3/8	1/2	110
ASM122Y	30.75	19.75	32.5	21.5	31.25	20.25	38.5	3/4	1 3/8	1/2	120
ASU180Y	63.25	19.75	65	21.5	63.75	20.25	36	3/4	(2) 1 1/8	(2) 1/2	300
ASU224Y	63.25	19.75	65	21.5	63.75	20.25	44	3/4	(2) 1 1/8	(2) 1/2	380

Model #	CFM	PD 40 deg.	Total/Sensible CAP 40 DEG Evap Temp 80/67 DEG ENT AIR	Total/Sensible CAP 40 DEG Evap Temp 80/67 DEG ENT AIR	Total/Sensible CAP 40 DEG Evap Temp 80/67 DEG ENT AIR
ASM92Y	3000	.14	111.5/76.0	92.2/68.0	72.1/60.2
ASM110Y	4000	.28	134.5/94.8	110.0/85.1	90.7/78.8
ASM122Y	4000	.25	146.9/101.3	122.8/91.5	95.3/80.8
ASU189Y	6000	.27	216.5/149.2	182.5/135.5	144.4/120.9
ASU224Y	8000	.30	260.9/183.9	224.3/170.4	185.4/157.5

Capacities calculated based on 103 deg. Refrigerant Temperature a Expansion device with 10 deg Superheat

SPECIFICATIONS SUBJECT TO CHANGE WITHOUT NOTICE