

# Light Commercial Horizontal Coils

6 Through 10 Ton Nominal Capacity

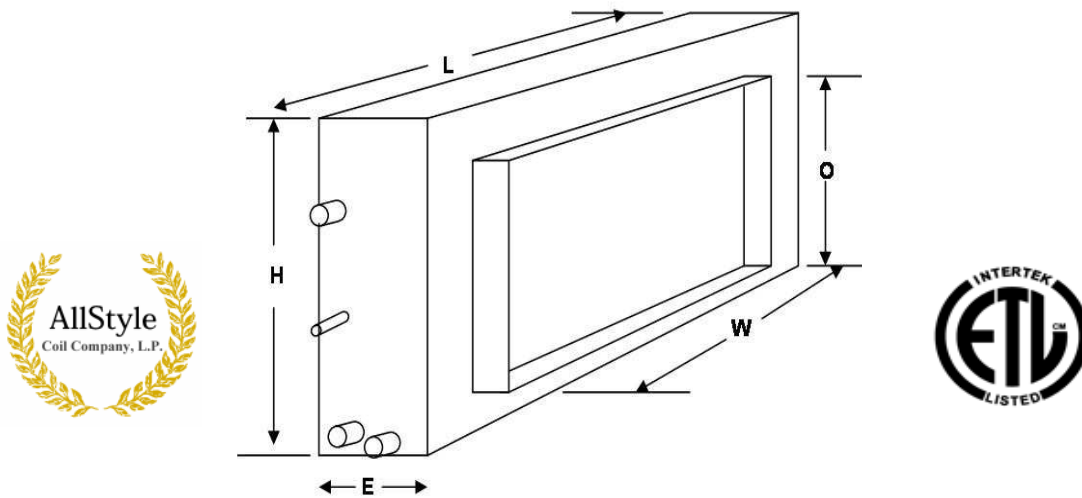

## Standard Features

Bi - Directional Airflow  
Embossed Galvanized Cabinet  
Single Stage Circuiting Standard

Expansion Valve Refrigerant Control  
Engineered Polymer Drain Pan  
Optional Dual Circuiting Available

## General Specifications

Model	W	O	E	L	H	Drain (MPT)	SUC	LIQ	Nominal Air-flow/pd	GR WT
ASH72X-1	36"	21"	16"	45"	24.5"	3/4"	7/8"	3/8"	2400CFM/.19	65#
ASH75X-1	36"	21"	16"	45"	24.5"	3/4"	7/8"	3/8"	2400CFM/.18	75#
ASH96X-1	36"	21"	16"	45"	24.5"	3/4"	1 1/8"	1/2"	3000CFM/.26	85#
ASH100X-1	36"	21"	16"	45"	24.5"	3/4"	1 1/8"	1/2"	3000CFM/.29	95#
ASH120X-1	36"	33"	16"	45"	36.5"	3/4"	1 3/8"	1/2"	4000CFM/.21	110#

## Total/Sensible Capacities, Btuh (80F, 67F wb Entering Air, 103F liq Temp)

Model	40F Evap Temp	45F Evap Temp	50F Evap Temp
ASH72X-1	81,909 / 57,493	69,939 / 52,949	55,982 / 47,892
ASH75X-1	88,573 / 60,757	76,691 / 56,213	62,543 / 54,004
ASH96X-1	106,730/73,785	90,338 / 67,267	73,217 / 61,181
ASH100X-1	117,431 / 80,071	101,904 / 74,039	84,162 / 67,562
ASH120X-1	138,739 / 80,071	122,513 / 74,039	101,863 / 67,592

# ASH SERIES HORIZONTAL 15-TON COILS



## PRODUCT FEATURES

- NOMINAL 15-TON COOLING CAPACITY
- HEAVY COPPER TUBE COIL WITH ALUMINUM FINNS
- SINGLE OR DUAL REFRIGERANT CIRCUITS
- FIXED ORIFICE OR EXPANSION VALVE REFRIGERANT METERING
- HEAVY GALVANIZED STEEL DRAIN PANS
- COILS ARE PRESSURE TESTED TO 450# BEFORE ASSEMBLY
- ATTRACTIVE AND RUST RESISTANT PAINTED STEEL CASING
- BI-DIRECTIONAL AIR FLOW
- ASH180 HAS 1 5/8" SUCTION LINE AND 5/8" LIQUID LINE
- 3/4" PRIMARY & SECONDARY DRAIN CONNECTIONS

Inlet and outlet plenum  
dimensions are the

