

ASM UP-FLOW "M" COMMERCIAL COILS



PRODUCT FEATURES

- CHOOSE BETWEEN 6 TO 10 TON NOMINAL CAPACITY
- HEAVY COPPER TUBE COIL WITH ALUMINUM FINS
- HEAVY ALUMINUM END PLATES
- SINGLE OR DUAL REFRIGERANT CIRCUITS
- FIXED ORIFICE OR EXPANSION VALVE REFRIGERANT METERING
- HEAVY GALVANIZED STEEL OR POLYCARBONATE DRAIN PANS
- COILS ARE PRESSURE TESTED TO 450# BEFORE ASSEMBLY
- ATTRACTIVE AND RUST RESISTANT PAINTED STEEL CASING

PRODUCT COOLING CAPACITY					
Model	Size	CFM	Capacity Total / Sensible 40° Evap Temp 80/67° Ent Air	Capacity Total / Sensible 45° Evap Temp 80/67° Ent Air	Capacity Total / Sensible 50° Evap Temp 80/67° Ent Air
ASM-90X	6-Ton	2400	90,475 / 62,017	77,910 / 57,123	62,889 / 51,486
ASM-92X	6-Ton	2400	92,350 / 63,106	80,149 / 58,302	65,389 / 52,811
ASM-102X	7.5-Ton	3200	102,316 / 71,741	89,714 / 67,368	74,016 / 61,959
ASM-112X	8-ton	4000	112,650 / 82,491	100,375 / 79,331	86,846 / 76,828
ASM-146X	10-Ton	4000	146,801 / 101,544	129,538 / 95,452	107,355 / 87,587
Capacities calculated at 103° entering liquid temperature.					
Specifications may change without notice.					

ASM UP-FLOW "M" COMMERCIAL COILS

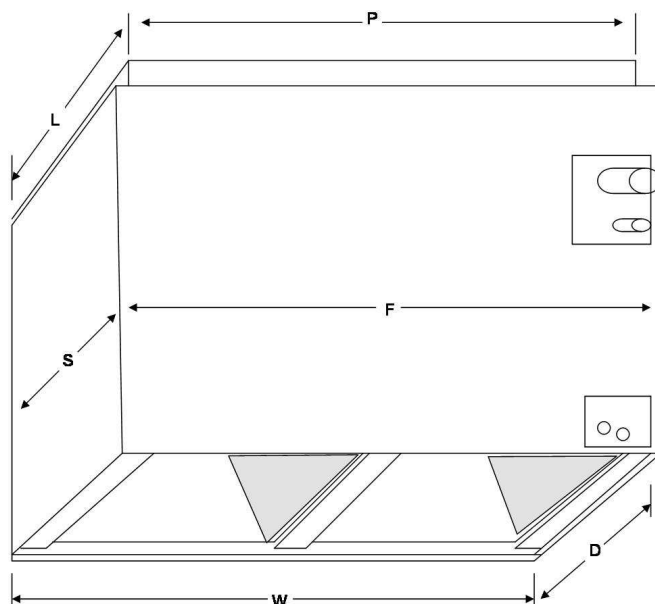

PRODUCT DIMENSIONS AND SPECIFICATIONS

MODEL	P	L	F	S	W	D	H	Drain Size	Nominal CFM
ASM-90X	40.25"	19.75"	42.00"	21.50"	40.75"	20.25"	24.00"	3/4"	2400
ASM-92X	40.25"	19.75"	42.00"	21.50"	40.75"	20.25"	24.00"	3/4"	2400
ASM-102X	40.25"	19.75"	42.00"	21.50"	40.75"	20.25"	24.00"	3/4"	3200
ASM-112X	50.25"	19.75"	52.00"	21.50"	50.75"	20.25"	24.00"	3/4"	4000
ASM-146X	50.25"	19.75"	52.00"	21.50"	50.75"	20.25"	24.00"	3/4"	4000

Specifications may change without notice. Patent # 5,284,027 Applies

ASM-90X & ASM92X have 7/8" Suction Line & 3/8" Liquid Line
 ASM-102X & ASM112X have 1 1/8" Suction Line & 1/2" Liquid Line
 ASM - 146X has 1 3/8" Suction Line & 5/8" Liquid Line

PRODUCT SPECIFICATIONS

Model	Pressure Drop	Rows	FP Inch	# of Slabs	Slab Dimensions	Refrigerant Circuits	Wt.
ASM-90X	.17"	2	14	4	16.5" x 18.0"	8	87
ASM-92X	.15"	2	14	4	16.5" x 20.0"	8	97
ASM-102X	.17"	2	14	4	16.5" x 22.0"	8	103
ASM-112X	.24"	2	14	4	16.5" x 24.0"	8	115
ASM-146X	.27"	3	12	4	16.5" x 24.0"	12	154

Specifications may change without notice. Patent # 5,284,027 Applies