

SLH / BLH SERIES AIR HANDLERS

The **SLH / BLH** series air handlers are designed for left or right hand horizontal installation. Various models are available to provide air movement from 400 to 1200 CFM. Optional slide-in coils for air conditioning and heat pump applications are available with nominal cooling capacities to 3 tons.



SLH / BLH Standard Features

All models are suitable for horizontal (left or right) installation. Cabinets are constructed of embossed galvanized steel that is fully insulated to provide thermal and acoustic protection. Non-corrosive nonmetallic drain pans are standard on all models. Optional electric heat elements in 3, 5, 6, 8, 10, 15, and 20 KW are constructed of nickel-chromium wire for long lasting dependable service. Twin circuit protection is provided in 15 and 20KW models. Multi speed permanent split capacitor direct drive blower motors are standard. A time delay fan relay and control voltage transformer are factory installed. All SLH and BLH models are 208 / 230 Volts single phase 60 hertz.

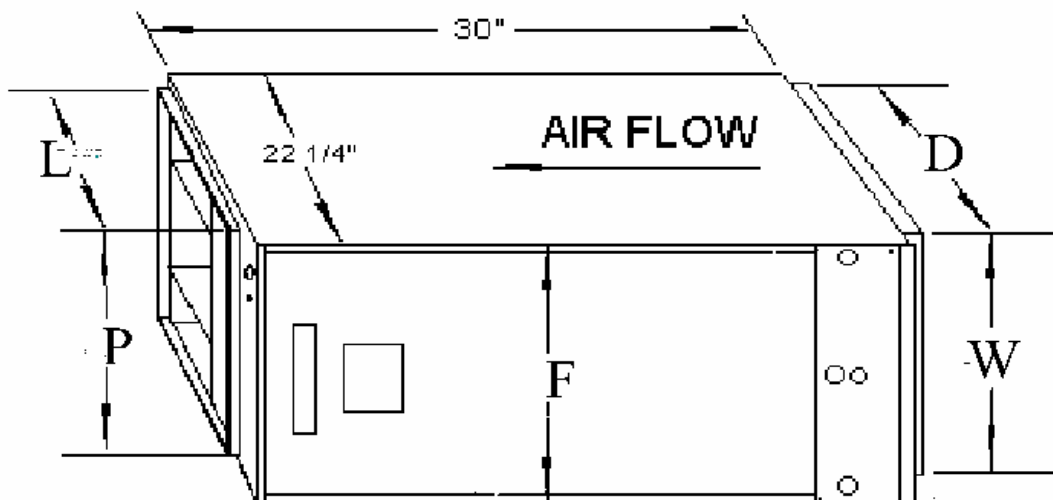

MODEL	F	P	L	W	D	SUCTION CONN	LIQUID CONN	DRAIN CONN
SLH	17.50"	16.00"	15.25"	16.00"	19.0"	3/4"	3/8"	3/4"
BLH	21.25"	19.75"	15.25"	19.25"	19.0"	3/4"	3/8"	3/4"

SLH / BLH SERIES AIR HANDLERS

Electrical Ratings

MODEL	KW@240	BTUH	TOTAL AMPS	MCA CKT 1	MCA CKT 2	MOP CKT 1	MOP CKT 2
SLH*/BLH*12/18/24-0	0	0	1.5	2	0	15	0
SLH*/BLH*12/18/24-3	3	10,257	14	18	0	20	0
SLH*/BLH*12/18/24-5	4.8	16,411	22	27	0	30	0
SLH*/BLH*12/18/24-6	6	20,512	27	34	0	40	0
SLH*/BLH*12/18/24-8	8	27,352	35	44	0	50	0
SLH*/BLH*12/18/24-10	9.6	32,822	42	52	0	60	0
BLH*30-0	0	0	3.0	4	0	15	0
BLH*30-3	3	10,257	16	20	0	20	0
BLH*30-5	4.8	16,411	23	29	0	30	0
BLH*30-6	6	20,512	28	35	0	40	0
BLH*30-8	8	27,352	37	46	0	50	0
BLH*30-10	9.6	32,822	43	54	0	60	0
BLH*30-15	14.4	49,234	63	54	25	60	30
BLH*36-0	0	0	3.0	4	0	15	0
BLH*36-3	3	10,257	16	20	0	20	0
BLH*36-5	4.8	16,411	23	29	0	30	0
BLH*36-6	6	20,512	28	35	0	40	0
BLH*36-8	8	27,352	37	46	0	50	0
BLH*36-10	9.6	32,822	43	54	0	60	0
BLH*36-15	14.4	49,234	63	54	25	60	30
BLH*36-20	19.2	65,649	83	54	50	60	30

To determine performance @ 208 V2C derate BTUH capacity 25%
 Refer to national electrical code to determine wire, fuse, and disconnect size
 15 and 20 KW models supply with factory installed twin circuit protection
 MCA= Minimum circuit ampacity MOP= Maximum over current protection (fuse or HACR breaker)

High Speed Blower Performance

MODEL	.1 ESP	.2 ESP	.3 ESP	.4 ESP	.5 ESP
SLH-12	665	615	500	420	340
SLH/BLH-18	745	700	640	580	500
SLH/BLH-24	950	900	825	745	650
BLH-30	1110	1060	1000	960	900
BLH-36	1315	1270	1200	1125	1040

Available Optional Accessories

3, 5, 6, 8, 10, 15, 20 KW Electric Heat
 Expansion or Check Valve Kits
 Circuit Breaker (10KW and less)
 Painted Cabinet