

*Meridian*

## 2AC13 13 SEER AIR CONDITIONERS



The Meridian 2AC13 series air conditioners utilize a very efficient and extremely durable Micro-Channel condenser coil. Developed about a half century ago for automotive radiators, and then used widely in heat exchanger coils for cars and trucks, Micro-Channel has proved its durability in literally millions of installations. It is less prone to damage than conventional copper tube aluminum fin coils. Because of its all aluminum construction, it is also less susceptible to corrosion than most other air conditioner condenser coils. Be a step ahead of your competition with the Meridian 2AC13.

### STANDARD FEATURES

#### COMPACT, HIGH EFFICIENCY DESIGN

**POWDER PAINTED  
GALVANIZED STEEL CASE WITH  
FULL LOUVERED EXTERIOR**

**SOUND ABSORBING  
INJECTION MOLDED TOP CAP**

**HIGH EFFICIENCY COMPRESSORS  
SCROLLS ON 2.5-TON & LARGER**

**HIGH EFFICIENCY  
MICRO-CHANNEL CONDENSER COIL**

**FACTORY INSTALLED  
LIQUID LINE FILTER DRIER**

**EASY ACCESS  
BRASS SERVICE VALVES**

**ONE FOOT PRINT  
1.5 THRU 5.0- TON SIZES**

**EASY SERVICE-ABILITY  
A SINGLE SCREW OPENS  
ELECTRICAL ACCESS PANEL**

**CONTRACTOR FRIENDLY  
R-22 REFRIGERANT**

**EASY COMPRESSOR SERVICE  
MAX HEIGHT IS 28.5 IN.**



**5-YEAR LIMITED COMPRESSOR WARRANTY  
5-YEAR LIMITED WARRANTY ON ALL FUNCTIONAL PARTS**

**Texas Furnace, LLC** 7037 Brittmore, Houston, Texas 77041 • 713 466 1504 • FAX 713 466 3648 • [www.texasfurnace.com](http://www.texasfurnace.com)



# 2AC13 13 SEER AIR CONDITIONERS

## 2AC13 DIMENSIONS

MODEL	A	B	C
<b>2AC13018</b>	<b>31.25</b>	<b>36.25</b>	<b>16.5</b>
<b>2AC13024</b>	<b>31.25</b>	<b>36.25</b>	<b>16.5</b>
<b>2AC13030</b>	<b>31.25</b>	<b>36.25</b>	<b>16.5</b>
<b>2AC13036</b>	<b>31.25</b>	<b>36.25</b>	<b>20.5</b>
<b>2AC13042</b>	<b>31.25</b>	<b>36.25</b>	<b>20.5</b>
<b>2AC13048</b>	<b>31.25</b>	<b>36.25</b>	<b>24.5</b>
<b>2AC13060</b>	<b>31.25</b>	<b>36.25</b>	<b>28.5</b>

All dimensions are measured in inches.

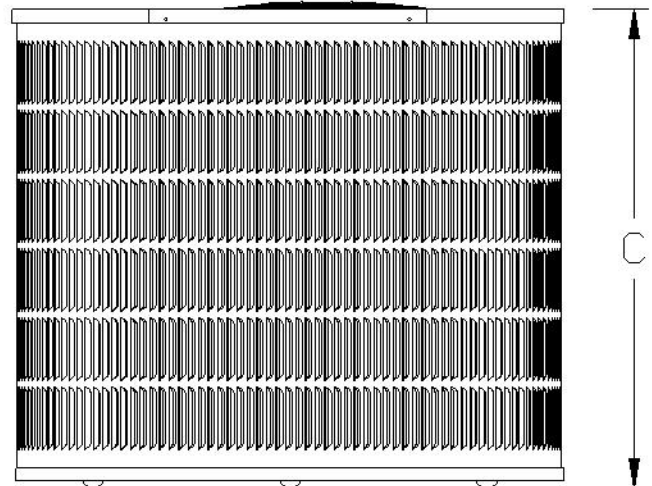
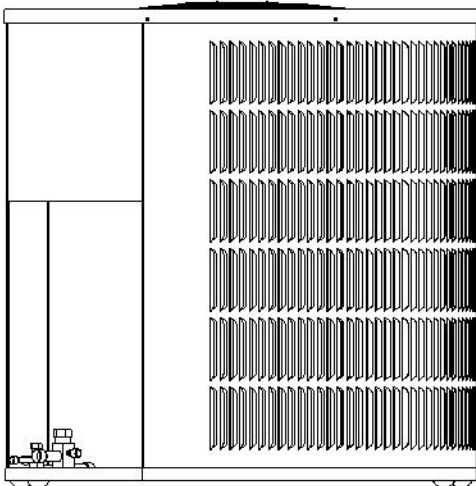
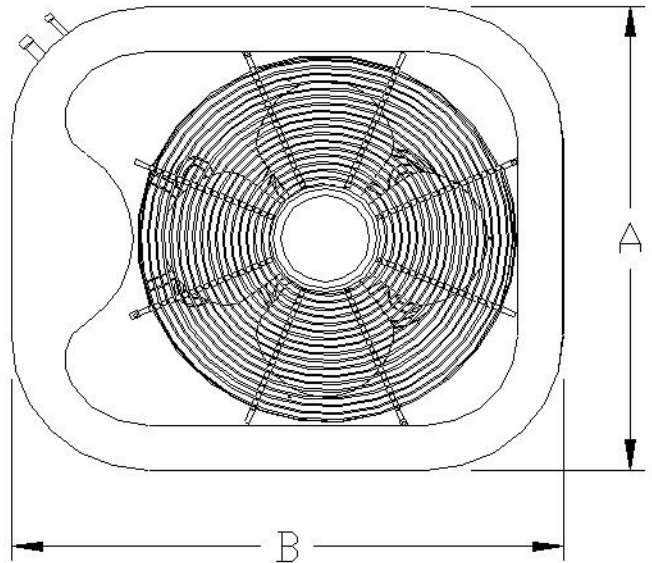

## ELECTRICAL CHARACTERISTICS

Model Number	Phase	Freq. (Hz)	Voltage	Compressor		Fan Motor Full Load Amps	Minimum Circuit Amperes	Fuse/HACR Circuit Breaker	
				Rated Amperes (RLA)	Locked Amperes (LRA)			Min	Max
2AC13018	1	60	208/230	8.4	39	0.9	12/12	15/15	15/15
2AC13024	1	60	208/230	11.3	51	0.9	16/16	20/20	25/25
2AC13030	1	60	208/230	13.6	67	0.8	18/18	25/25	30/30
2AC13036	1	60	208/230	16.0	77	0.8	21/21	30/30	35/35
2AC13042	1	60	208/230	18.4	95	1.5	25/25	35/35	40/40
2AC13048	1	60	208/230	20.4	109	1.5	27/27	35/35	45/45
2AC13060	1	60	208/230	28.0	148	1.8	37/37	45/45	60/60



# 2AC13 13 SEER AIR CONDITIONERS

**Designed by contractors, for contractors!**



Removing.....

**just one screw**

**and the electrical control box cover slides down giving full access to all operating controls!**



### UNIT SPECIFICATIONS

	1.5	2	2.5	3	3.5	4	5
Nominal Capacity	1.5	2	2.5	3	3.5	4	5
Model Number	2AC13018	2AC13024	2AC13030	2AC13036	2AC13042	2AC13048	2AC13060
Rated BTUH	18000	24000	29000	34000	41000	46000	57000
SEER	13.0	13.0	13.0	13.0	13.0	13.0	13.0
Compressor Type	Reciprocating		Compliant Scroll				
Compressor Manufacturer	Copeland						
Condensing Coil	All Aluminum Micro-Channel Design						
Liquid Line Connection	3/8"	3/8"	3/8"	3/8"	3/8"	3/8"	3/8"
Suction Line Connection	3/4"	3/4"	3/4"	3/4"	7/8"	7/8"	7/8"
Refrigerant	R-22	R-22	R-22	R-22	R-22	R-22	R-22
Cabinet	Fully Louvered Galvanized Steel with Powder Coat Protection						

*Meridian*

2AC13 13 SEER  
AIR CONDITIONERS

## ALL ALUMINUM MICRO-CHANNEL CONDENSER COIL

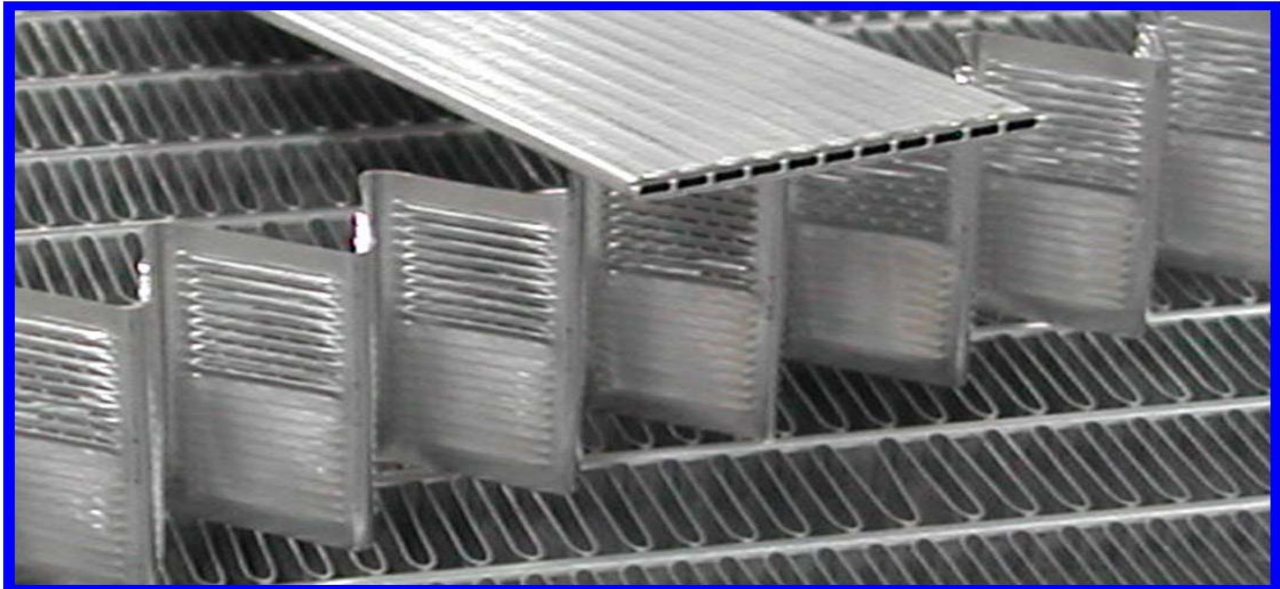

### **What is Micro-Channel?**

The Micro-Channel coil was developed by the automotive industry. It has been used in cars and trucks for over 25 years. The coil consists of multiple flat aluminum tubes containing precise channels the refrigerant flows through. Air passes over the flat tubes and the aluminum fins that are sandwiched between two layers of tubes and then braised.

### **What are the benefits of Micro-Channel?**

- More efficient than traditional copper /aluminum condensers, therefore smaller
- Uses about 40% less refrigerant than copper/aluminum condensers
- Greatly reduced braised connections – less chance for leaks
- Much tougher than copper/aluminum. Standing on the coil does not bend the fins.
- The smaller coil allows for a smaller cabinet, less metal, less refrigerant, less freight, and less warehouse space.

### **Why is Micro-Channel More Efficient?**

The Micro-Channel provides more surface area for the air to contact and the air is in contact with the flat tube longer than a round tube. This provides better heat transfer. The fins are braised to the flat tubes which improves heat transfer than mechanically fitted aluminum fins on copper tubes.

Micro-Channel offers less resistance to the airflow allowing more air to pass through the coil with less fan capacity.